

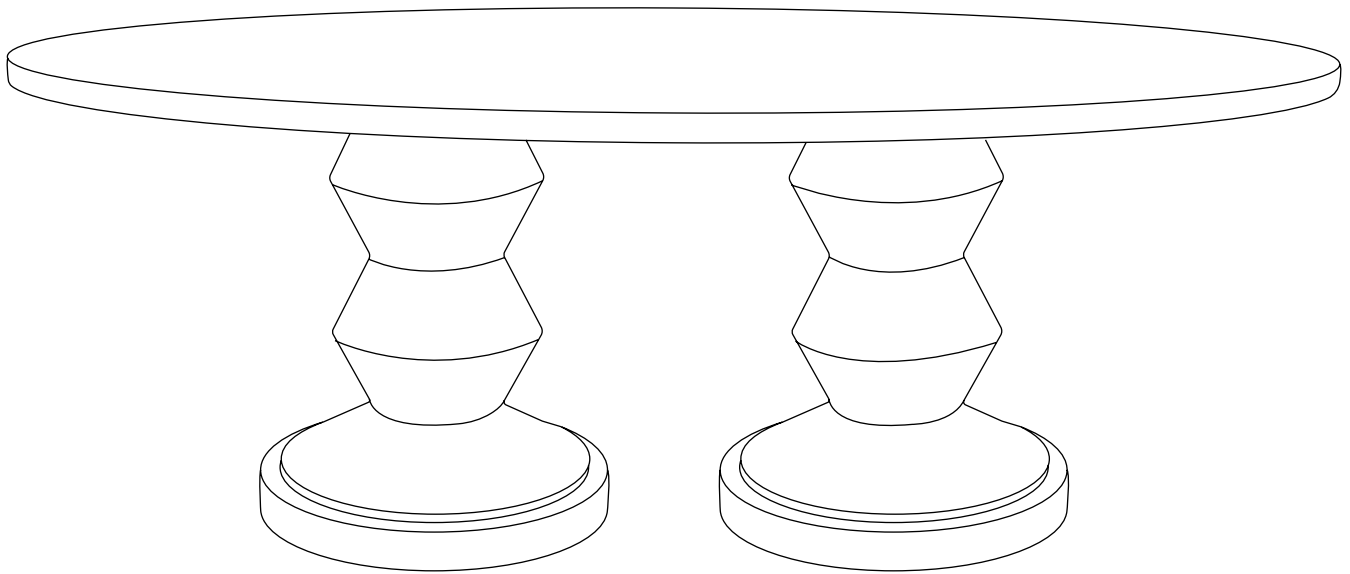

MADE GOODS

MONTGOMERY DINING TABLE ASSEMBLY INSTRUCTIONS



Tools and Materials Required:

Padded, flat, nonabrasive work surface, such as a blanket

PARTS LIST

· Tabletop (A) - 1

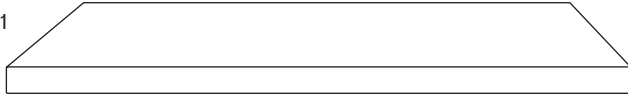

Square
40"

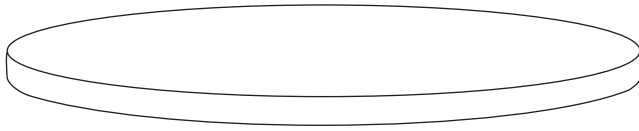

Round
48"-60"



Oval
84", 96"

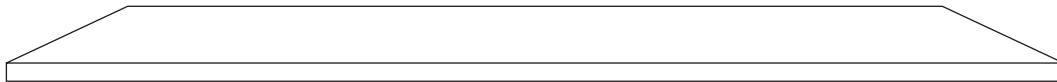

Rectangular
72", 88", 110"

· Table Base (B)

- Square or Round, x1
- Rect. or Oval, x2



Before Beginning

1. Unpack box contents onto a scratch-free surface.
2. Place base in desired location. Make sure the location is perfectly flat/level.

INSTALLATION INSTRUCTIONS

1. Place the tabletop (A) above the table base (B). Following the proper spacing instructions provided ensures the stability and safe usage of each assembled piece and eliminates issues caused by improper placement of the base(s).
2. For square or circle tabletops (A), center the tabletop (A) on the base (B).

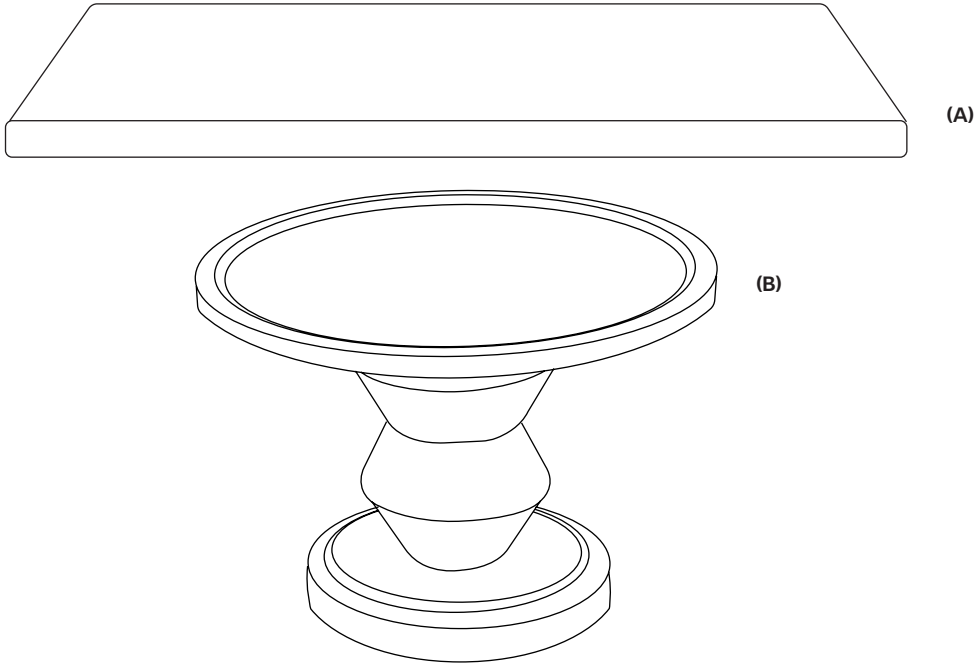

40" SQUARE TABLETOP

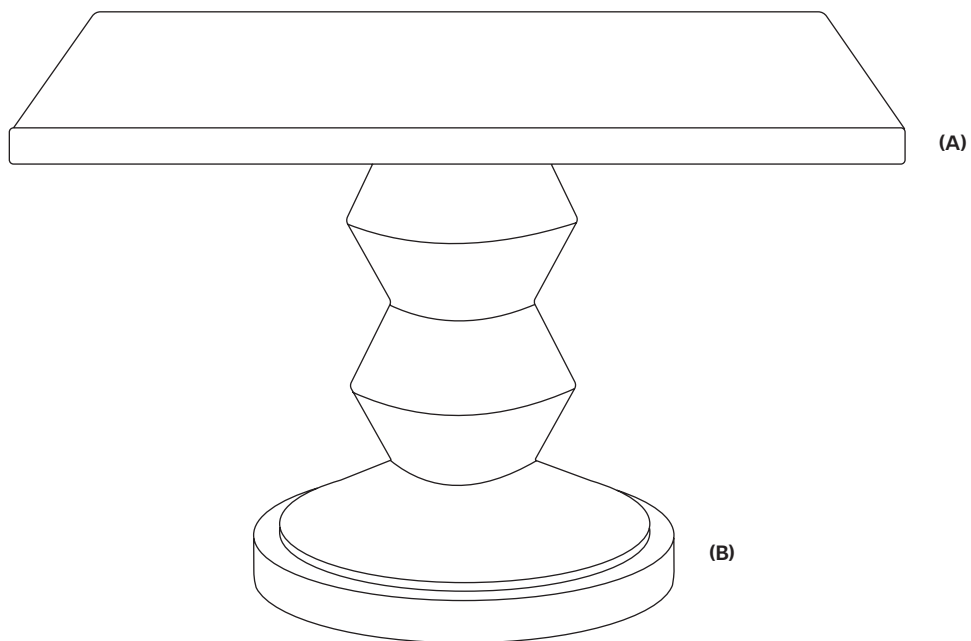

48"-60" ROUND TABLETOP

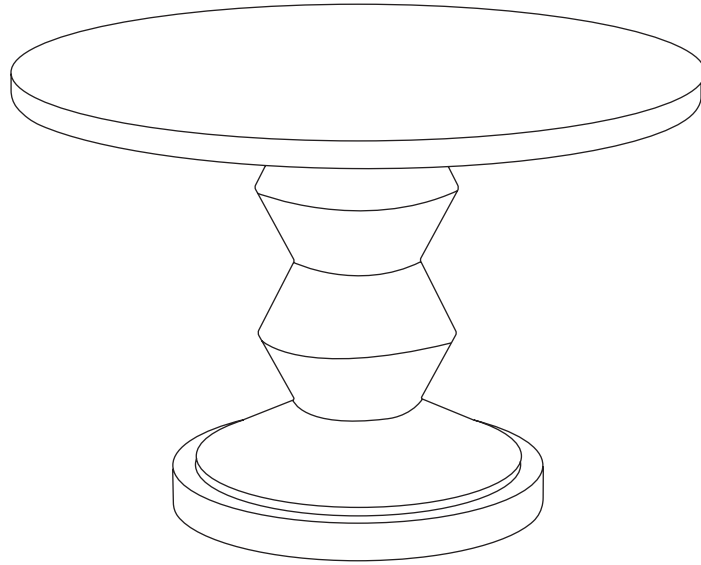

84" OVAL TABLETOP

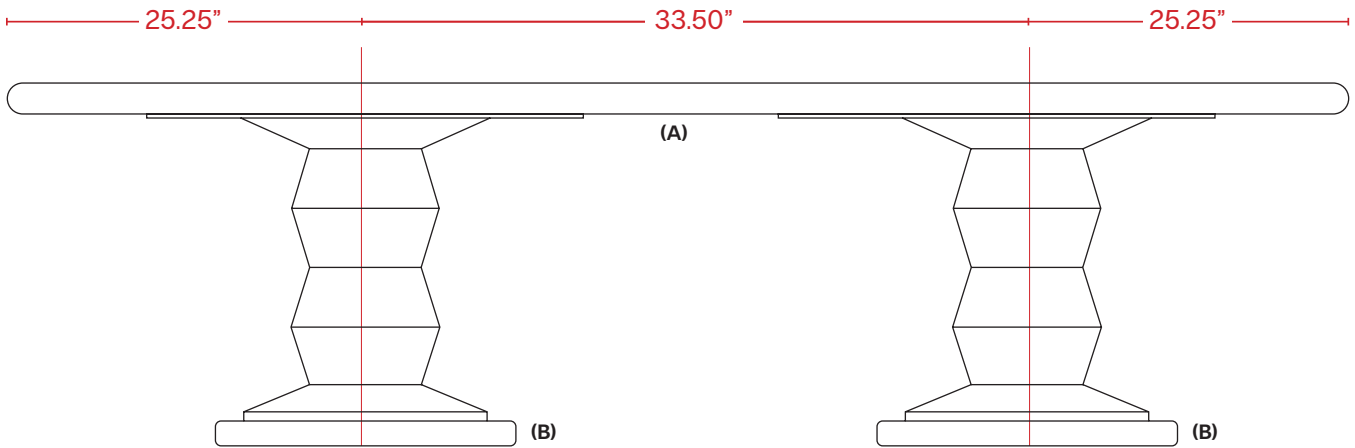

96" OVAL TABLETOP

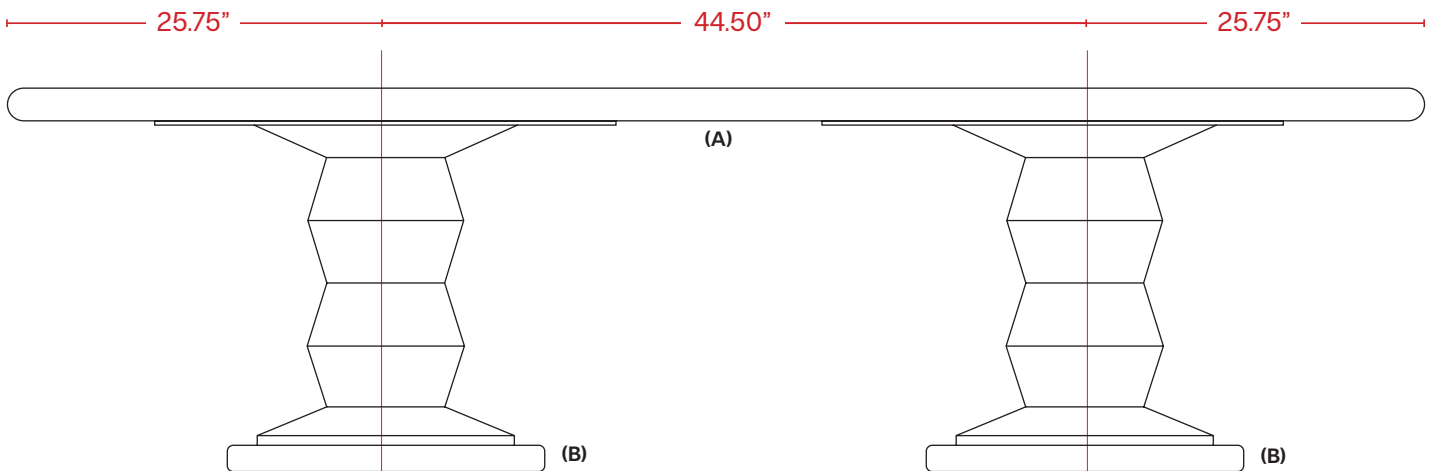

72" RECTANGULAR TABLETOP

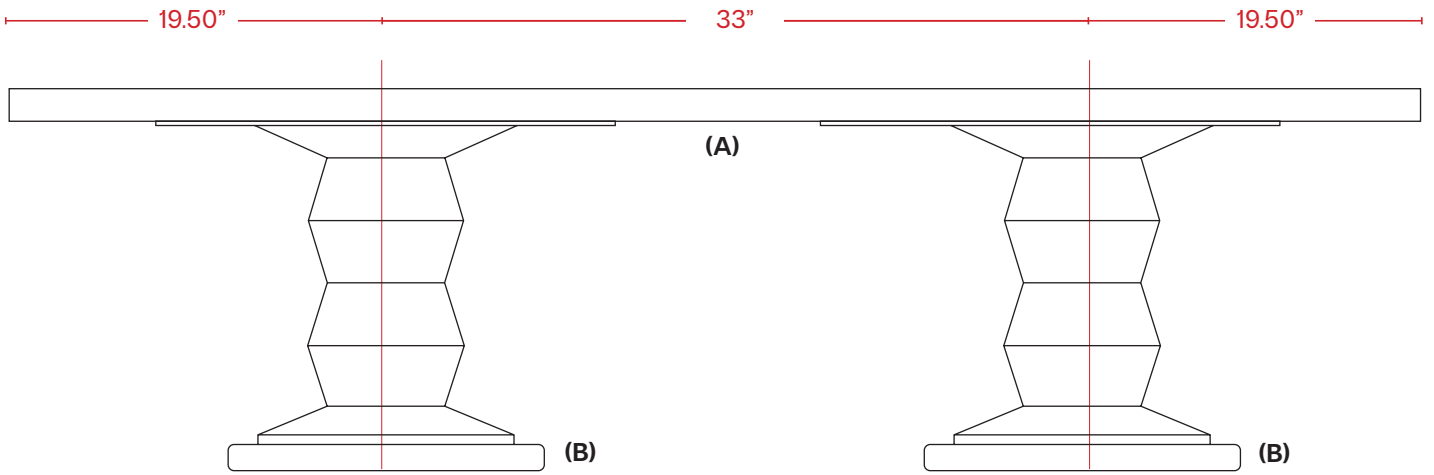

88" RECTANGULAR TABLETOP

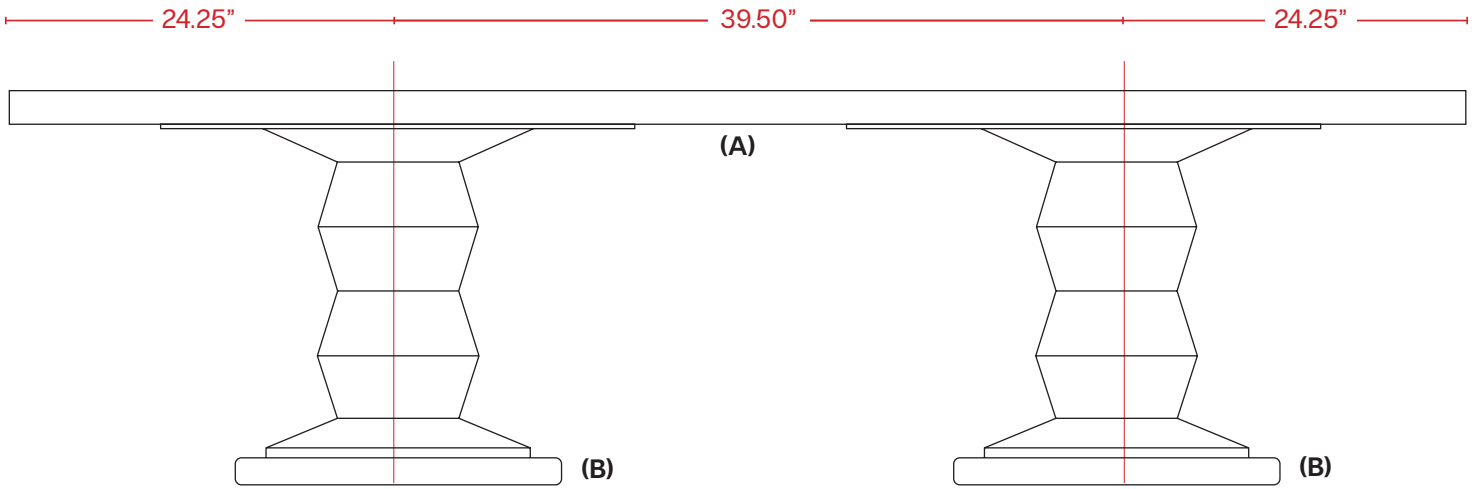

110" RECTANGULAR TABLETOP

